

[Http://www.parsun.com.cn](http://www.parsun.com.cn)

 PAR SUN

百胜

零件目錄

PARTS CATALOGUE

Electric Start

F25 (F20)

FW

苏州百胜动力机器有限公司

SUZHOU PARSUN POWER MACHINE CO., LTD

目次

CONTENTS

电气	1~2
ELECTRICAL	1~2
起动器	3
STARTER	3
气缸和曲轴箱	4
CYLINDER&CRANKCASE	4
底罩和托架	5~6
BOTTOM COWLING & BRACKET	5~6
操纵盒组件	7~9
CONTROL BOX ASSY	7~9

零部件名称:

电气

PARTS NAME:

ELECTRICAL

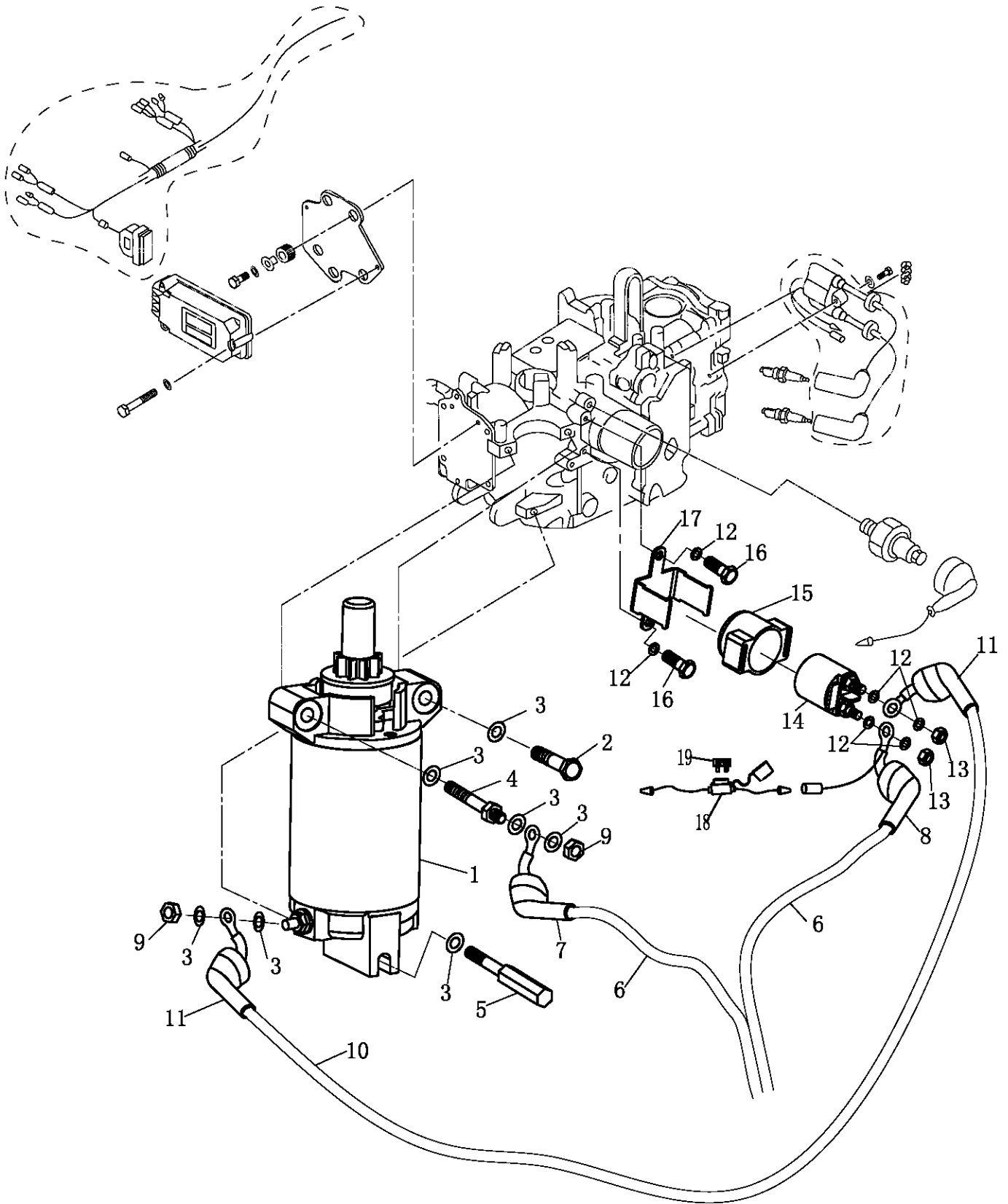

零部件名称: 起动机

PARTS NAME: STARTER

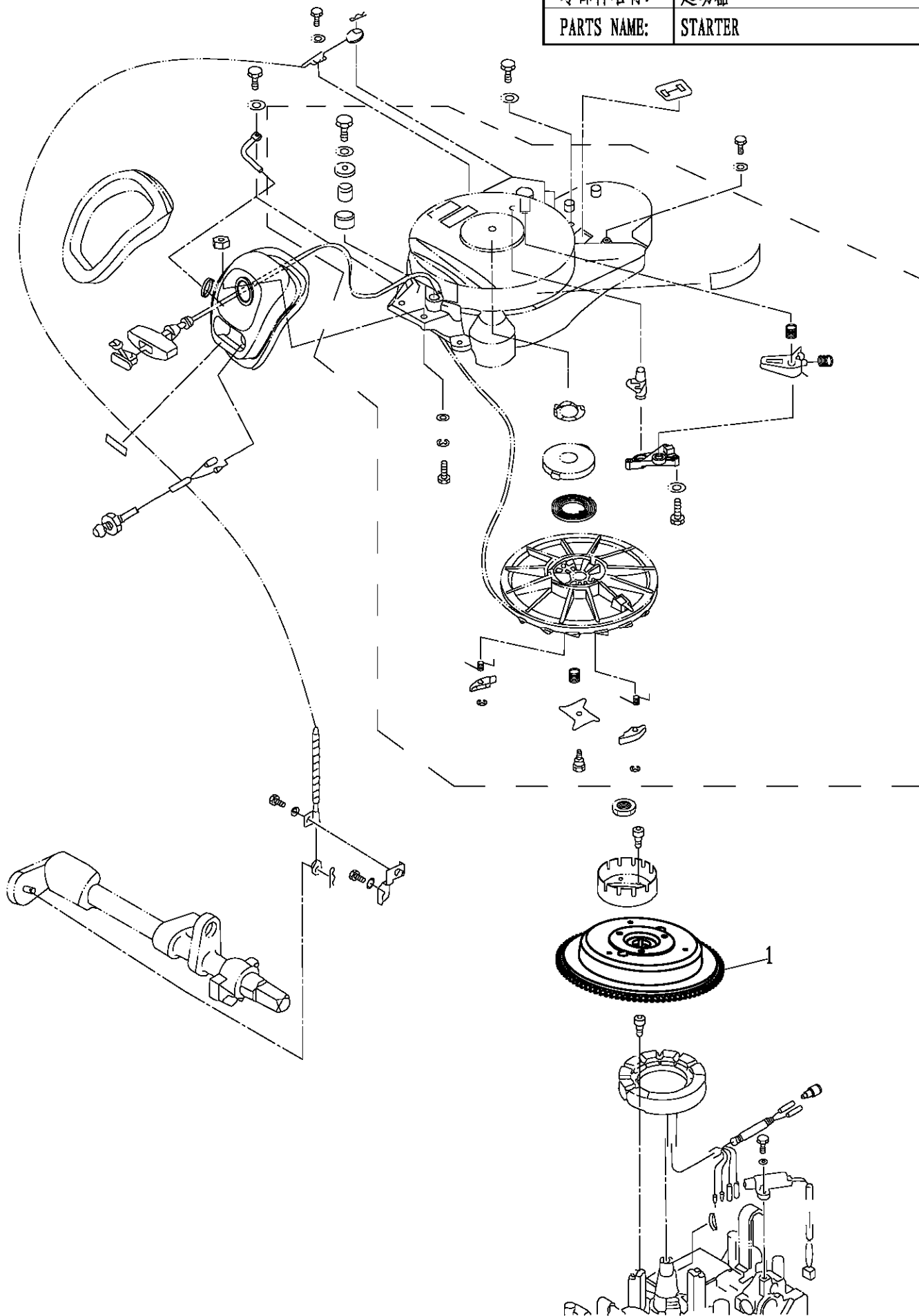

SN. 参照号码	PART NO. 零件编号	DESCRIPTION 零件名称(中文)	DESCRIPTION 零件名称(英文)	QTY 数量				REMARKS 备注
1	F25-0518000W	飞轮组件	FLYWHEEL, ASSY	1				

零部件名称:

气缸和曲轴箱

PARTS NAME:

CYLINDER&CRANKCASE

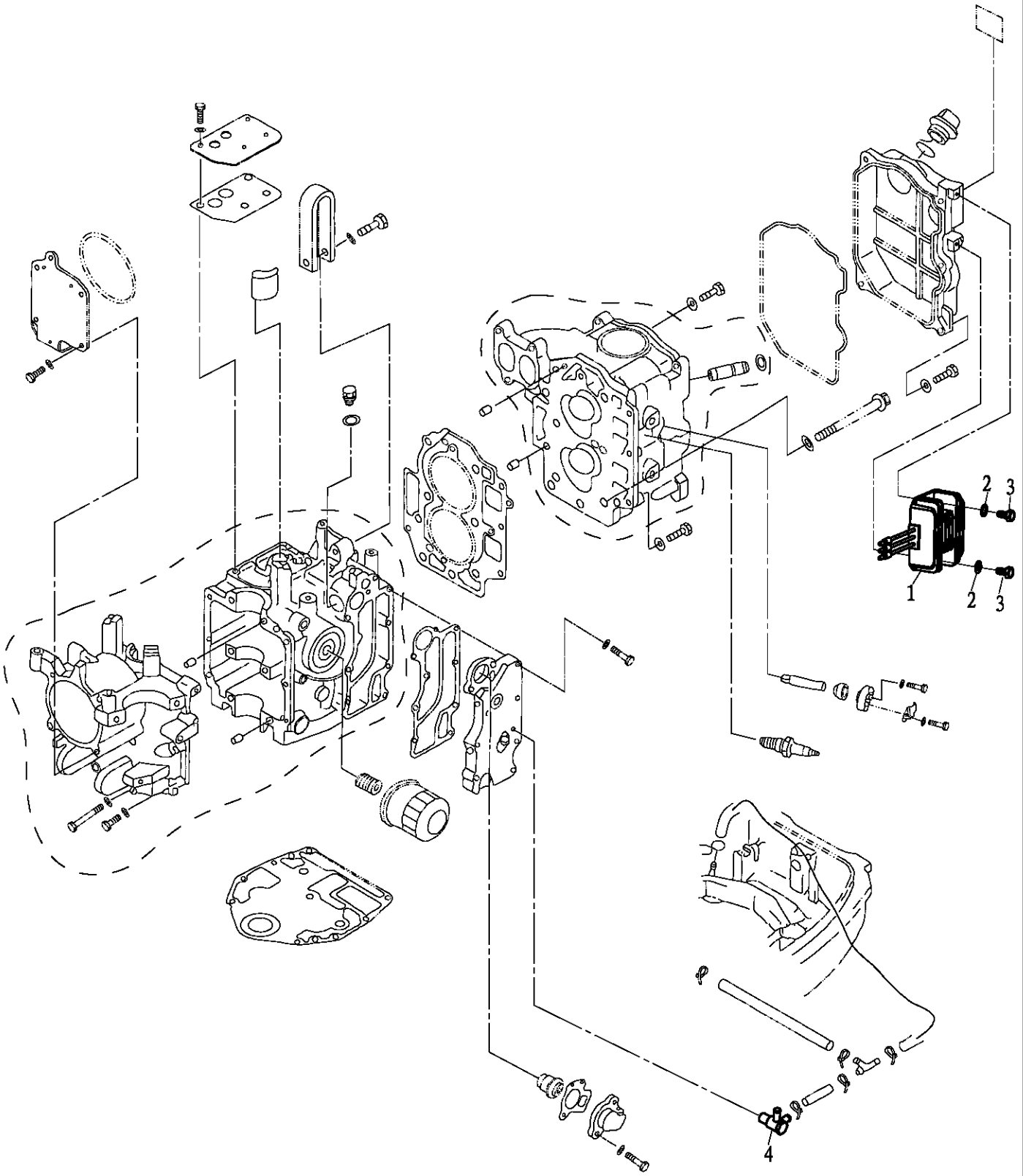

SN. 参照号码	PART NO. 零件编号	DESCRIPTION 零件名称(中文)	DESCRIPTION 零件名称(英文)	QTY 数量				REMARKS 备注
1	F25-05170500W	整流器组件	RECTIFIER ASSY	1				
2	GB/T97.1-6	平垫圈 6	WASHER 6	2				
3	GB/T5783-M6x12	六角螺栓M6x12	BOLT, HEXAGON M6X12	2				
4	F25-05010400W	出水嘴接头组件	NOZZLE, ASSY	1				

零部件名称:

底罩和托架

PARTS NAME:

BOTTOM COWLING & BRACKET

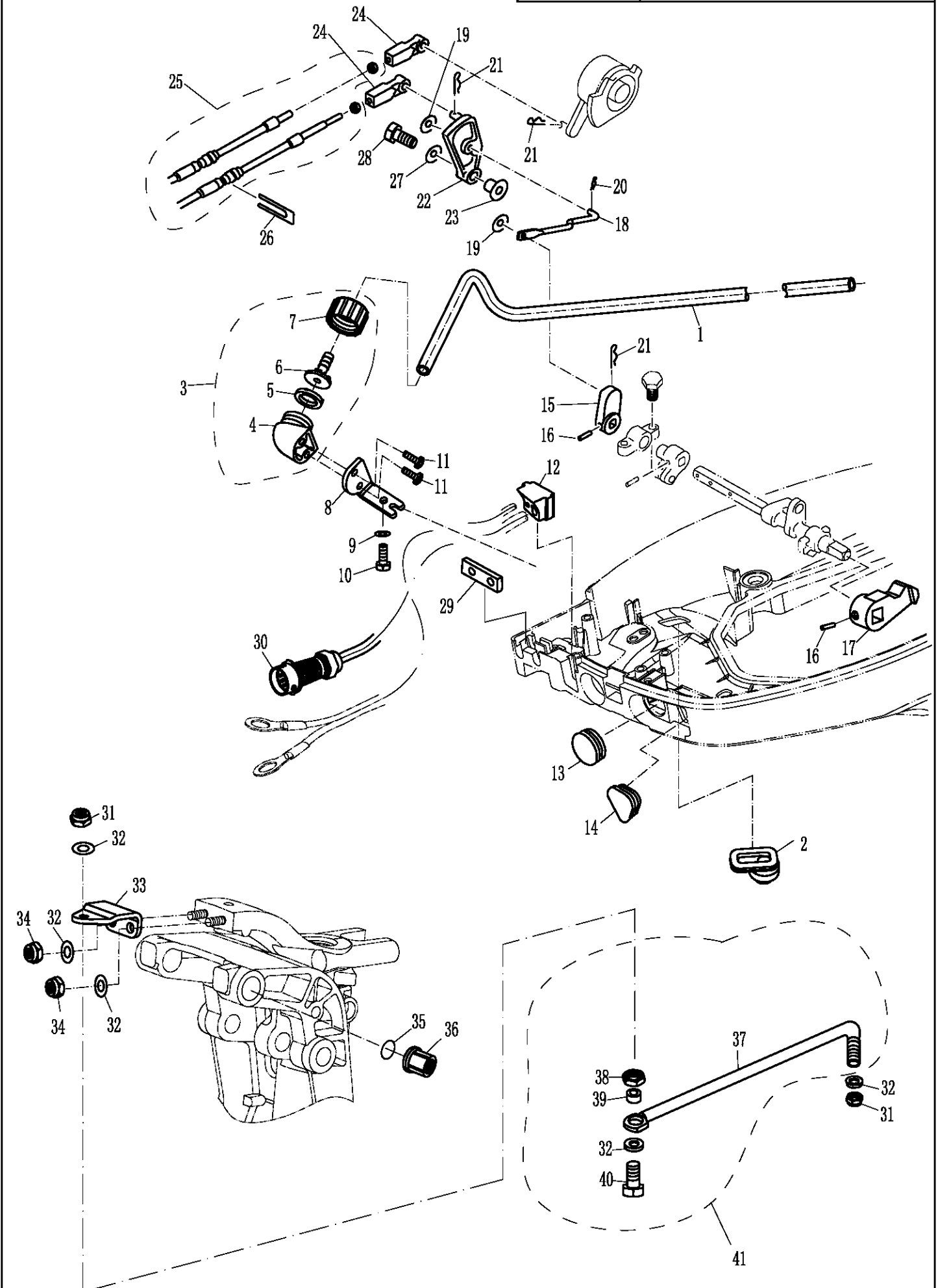

零部件名称:

操纵盒组件

PARTS NAME:

CONTROL BOX ASSY

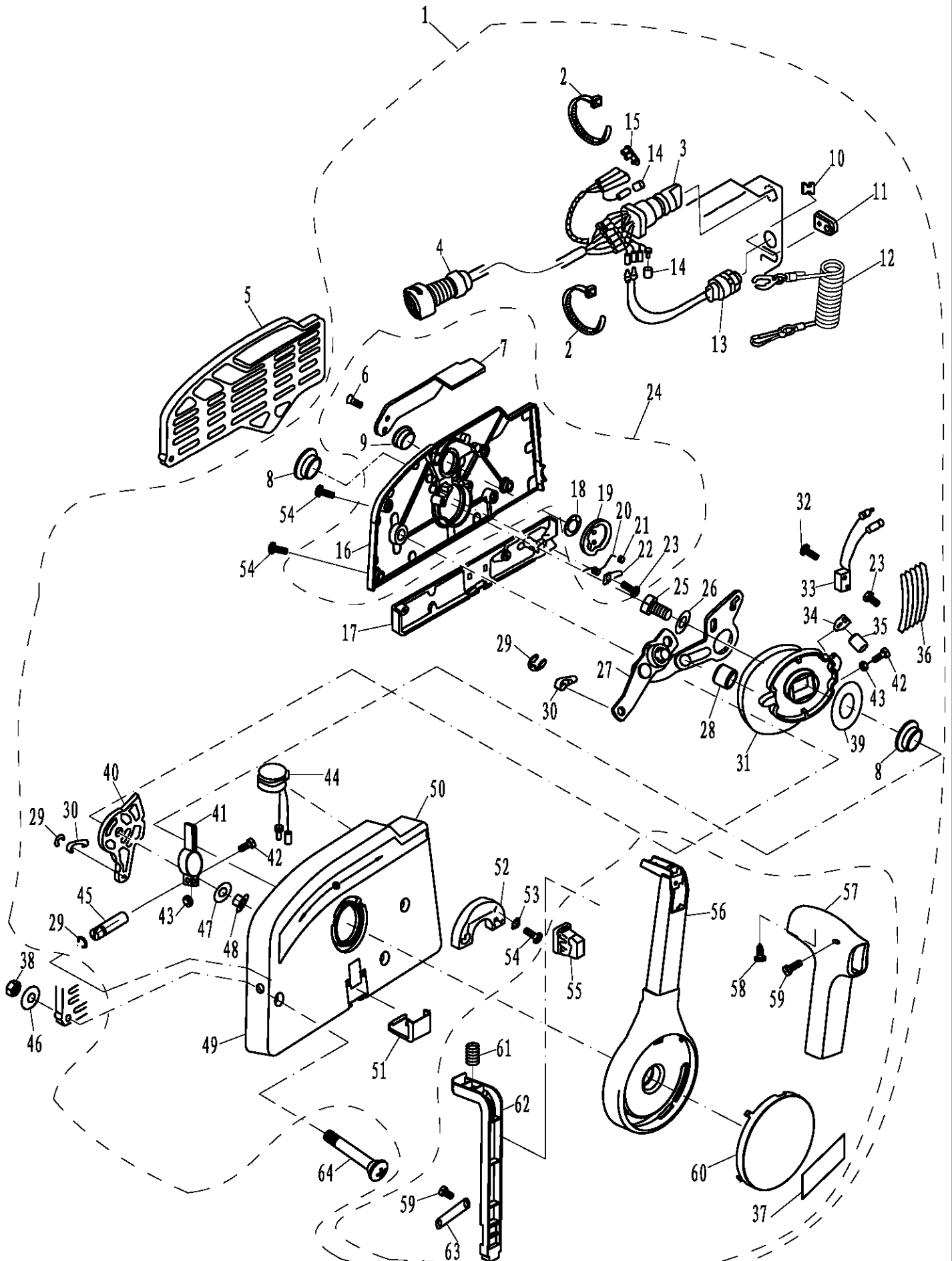

零部件名称:

操纵盒组件

PARTS NAME:

CONTROL BOX ASSY

SN. 参照号码	PART NO. 零件编号	DESCRIPTION 零件名称(中文)	DESCRIPTION 零件名称(英文)	QTY 数量					REMARKS 备注
1	F25-11000000W	操纵盒组件	CONTROL BOX ASS'Y	1					
2	HT2.5*60	尼龙扎带	CLAMP	2					
3	F15-13000200W	起动开关组件	STARTING SWICH ASS'Y	1					
4	F15-13000100W	操纵线束组件	CONTROL CABLE ASS'Y	1					
5	F15-11000002W	操纵盒安装板	PLATE , CONTROL BOX	1					
6	GB/T819.2-M5x12	十字槽沉头螺钉 M5x12	SCREW PAN HEAD M5X12	2					
7	F15-13020007W	油门微调手柄	THROTTLE HANDLE , INCHING	1					
8	F15-13000005W	凸轮机构衬套	BUSH , CAM	2					
9	F15-13020006W	微调手柄衬套	BUSH , HANDLE	1					
10	F15-11000001W	钢索橡胶垫块	BLOCK , RUBBER	1					
11	F15-13000014W	线束护套	JACKET , CABLE	1					
12	F4-01090401	引擎停止安全索	STOPER , HANG ROPE ASS'Y	1					
13	F15-13020400W	急停开关组件	ENGINE STOP SWICH ASS'Y	1					
14	F15-13000203W	绝缘堵头 B	INSULATED PLUG "B"	2					
15	F15-13000202W	绝缘堵头 A	INSULATED PLUG "A"	1					
16	F15-13020001W	操纵盒盖	COVER , CONTROL BOX	1					
17	F15-13000013W	操纵盒小盖板	SMALL COVER , CONTROL BOX	1					
18	F15-13020005W	波形垫圈 B	WASHER "B" , WAVE	1					
19	F15-13020100W	锁紧圆盘组件	LOCKED DISK ASS'Y	1					
20	F15-13020002W	扭簧	TORSION SPRING	1					
21	F15-13020003W	互锁滑轮	EACH LOCKED PULLEY	1					
22	F15-13020004W	滑轮弹簧压板	PLATE , PULLEY SPRING	1					
23	GB/T818-M4x6	十字槽盘头螺钉M4x6	PAN HEAD SCREW M4X6	2					
24	F15-13020000W	操纵盒盖组件	COVER ASS'Y, CONTROL BOX	1					
25	GB/T5783-M8x30	六角螺栓 M8x30	BOLT M8X30	1					
26	GB/T97.1-8	平垫圈 8	WASHER 8	1					
27	F15-13000500W	油门控制机构	MACHINE , CONTROL ACCBLEROGRAPH	1					
28	F15-13000007W	销轴垫圈	WASHER	1					
29	GB/T896-6	开口挡圈 6	PIN , COTTER 6	3					
30	F25-07000007W	操控钢索接头 B	CONTROL CABLE TIE-IN "B"	2					
31	F15-13000002W	凸轮机构	CAM MECHANISM	1					
32	GB/T818-M3x14	十字槽盘头螺钉M3x14	PAN HEAD SCREW M3X14	2					
33	F15-13000800W	微动开关	INCHING SWITCH	1					
34	F15-13000003W	档位弹簧片压板	PLATE	1					
35	F15-13000004W	档位滑轮	PULLEY	1					
36	F15-13000001W	档位弹簧片 B	SHIFT SPRING PLATE "B"	5					
37	F15-12000016W	标贴 16	MARK 16	1					
38	GB/T6170-M6	六角螺母 M6	NUT M6	3					
39	F15-13000008W	凸轮机构减磨片	WEARABLE PLATE , CAM MACHANISM	1					
40	F15-13000700W	变档摆杆	SHIFT SWING LINK	1					
41	F15-13000601W	调节器固定板组件	ADJUSTER FASTNESS ASSY	1					
42	GB/T5783-M5x25	六角螺栓 M5x25	BOLT M5X25	2					
43	GB/T6170-M5	六角螺母 M5	NUT M5	2					

